

**INSTRUCTIONS AND SAFETY MANUAL**

**SPORT KITES**  
**ATOM | ORBIT | PULSAR | FURY**



Thank you for purchasing your new **Flexifoil performance sport kite**. Before flying your kite, **you should take time to read** and understand these instructions and safety warnings.

**Instructions include:** safety, wind terminology, assembly, launching, basic flying, landing, packing away, tuning tips and care and maintenance.

**You can download this manual and any updates from**  
**[www.flexifoil.com/downloads](http://www.flexifoil.com/downloads)**

### SAFETY FIRST

⚠ Flexifoil strongly recommend that you abide by **ALL** safety guidelines and conduct yourself in a safe manner at all times

- **NEVER** fly your kite in conditions that are too extreme or winds that are too strong for your skill level or your equipment i.e. **ALWAYS** learn to fly in lighter winds before attempting to fly in stronger winds
- **ALWAYS** check your equipment for wear and tear before flying. **DO NOT** fly with worn or damaged equipment. Repair or replace accordingly
- **ALWAYS** select safe launching and landing areas free of people and obstacles. Disable your kite and lines on the ground when not in use
- Flying lines and bridles under tension can cut like a knife. Always keep your lines away from people and animals. **NEVER** attempt to catch or hold a kite by the lines or bridle
- **DO NOT** fly your kite near power lines, in storms, near airports, roads, railways, people or animals

⚠ Remember, **YOU** are responsible for the safe operation of your kite and equipment at all times



### SPORT KITE PACKAGE INCLUDES



### SAFE FLYING

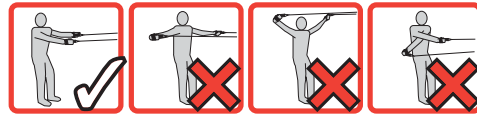

Ensure you have the correct flying position.

### THE WIND WINDOW

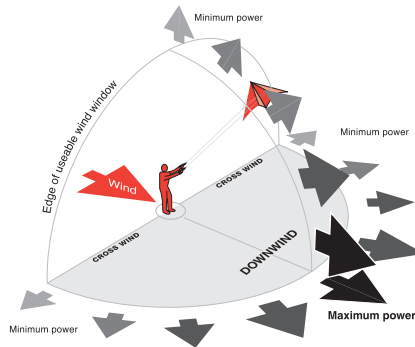

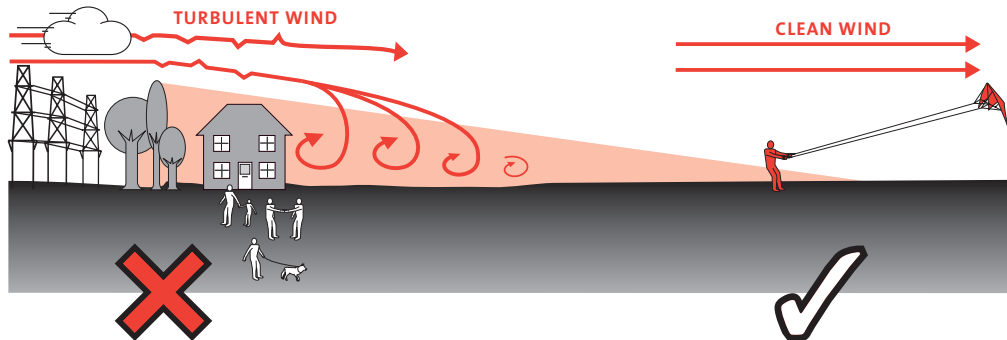

- ⚠ When launching kites in strong winds, **ALWAYS** launch at the edge of the wind window
- ⚠ Weather conditions can be unpredictable and can change very quickly. **ALWAYS** be vigilant and respect the power of the wind

### CHOOSE YOUR FLYING SITE CAREFULLY

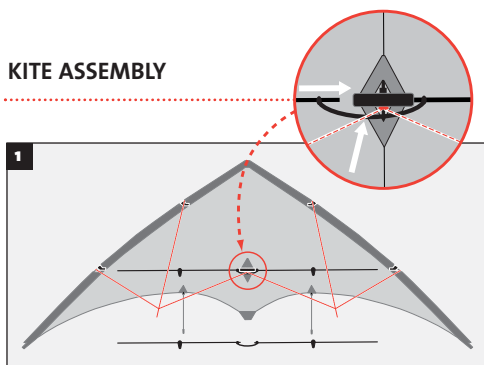

### KITE ASSEMBLY



  **Note - the Atom Sport Kite does not have the upper spreader**

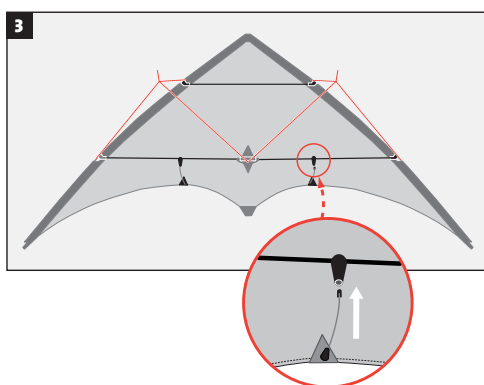
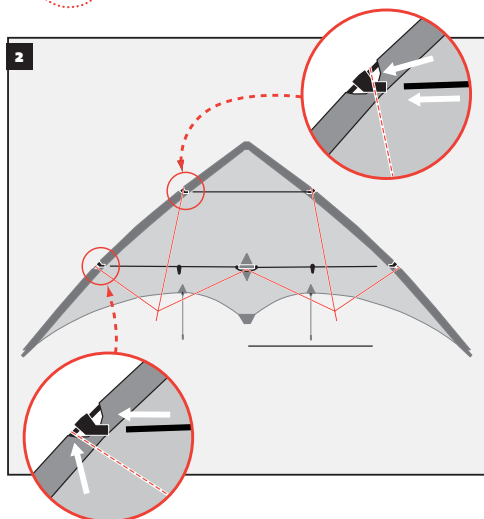

### HOW TO MAKE THE LARKS-HEAD KNOT

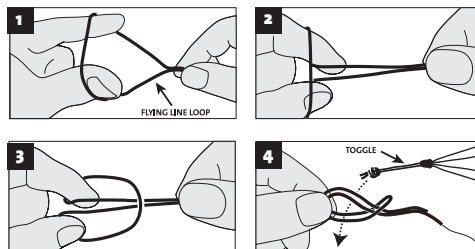

 All line to kite connections are made using a larks-head knot. The diagrams above show you how to make the larks-head knot in the loops at the ends of your flying lines

### CONNECTING LINES TO CONTROL GEAR / KITE

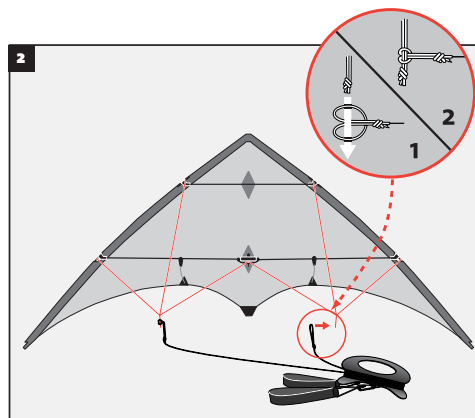
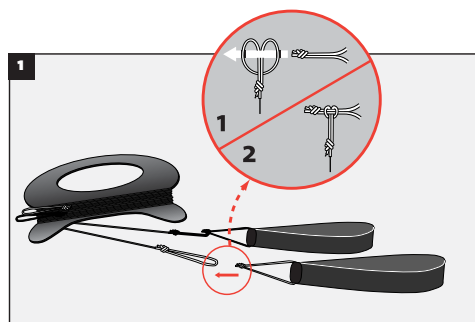

## LAUNCHING THE KITE

⚠ Ensure your flying lines are unwound completely before launching

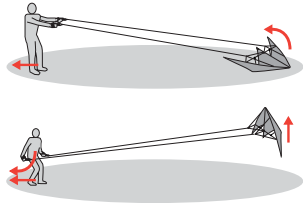

⚠ Please refer to the 'Wind Window' diagram for instructions on where to best launch your kite.

## FLYING THE KITE

⚠ Do not crash the kite into the ground as this will damage the kite

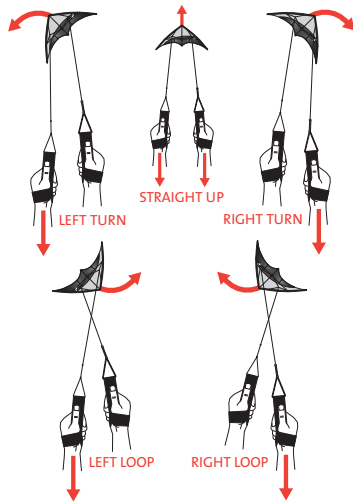

## LANDING AND SECURING THE KITE

⚠ Do not crash the kite into the ground as this will damage the kite

For a safe landing steer the kite to the edge of the wind window. It will sink gently to the ground. Secure your kite to the ground by inserting a ground stake through the straps.

⚠ NEVER leave your kite unattended. If you have finished flying, pack it away for safety

## PACKING AWAY YOUR KITE

We recommend that you disconnect your lines from your kite. Store your lines on the line winder by winding in a figure-of-eight motion.

**IMPORTANT:** To avoid twists in the lines, it is vital that the next time you use your kite, you unwind the lines in the same way as you wound them on; i.e. the unwinding action must be the exact reverse of the winding action.

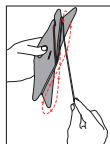

Disassemble kite and place in bag.

## TUNING TIPS / TROUBLESHOOTING

If your kite is flying incorrectly you may need to adjust the lengths of your flying lines (Adult supervision may be necessary).

See [www.flexifoil.com/tips](http://www.flexifoil.com/tips) for more information.

## CARE AND MAINTENANCE

⚠ Taking good care of your kite will prolong its life

**AVOID** flying your kite near trees, hedges, stone walls, barbed wire fences or other obstacles that could damage your kite.

**DO NOT** drag your kite across the ground when trying to launch or land, especially in stubble fields, on stony beaches or on other abrasive surfaces that could damage your kite.

**NEVER** store your kite wet. Always allow it to dry before packing and storage.

Your kite can be hand-washed with care in warm **NOT HOT** soapy water. Use a mild detergent, i.e. washing up liquid, and a soft sponge.

**DO NOT** use a washing machine or tumble dryer!

**ALWAYS** check your equipment for wear and tear before using it and repair or replace accordingly.

## REPAIRS SERVICE

**Damaged your kite?** Flexifoil kites have been designed to be strong and durable. However, they are not indestructible. If they are crashed hard into the ground or dragged they may get damaged. For this reason we have a repair service available.

### ONE MONTH FREE REPAIR OFFER

Sport kites are covered by our One Month Free Repair Offer. If you damage your kite within one month of purchase, we will repair it free of charge! Please follow the instructions on the Free Repair Voucher you received with your kite or visit [www.flexifoil.com/repairs](http://www.flexifoil.com/repairs) for more details.

### STANDARD REPAIR SERVICE

If you damage your kite when the One Month Free Repair Offer has expired, Flexifoil offer a quick and inexpensive repair service to all its customers. We also stock spare parts and sails for both current and discontinued kites. You can repair small tears with Flexifoil self adhesive repair tape. For larger and more complicated repairs, we recommend that you return your kite to Flexifoil International.

Flexifoil undertake most repairs at their factory but **overseas customers should contact their local distributor for assistance.** Please visit [www.flexifoil.com/repairs](http://www.flexifoil.com/repairs) for the latest info.

## WARRANTY

At Flexifoil we believe in designing and manufacturing our products to the highest possible standards. We pride ourselves on our outstanding quality control but if any of our products fail as a result of defective workmanship or faulty materials, we will replace it free of charge. This is in addition to your statutory rights.

Products will not be replaced which have been:

- damaged as a result of normal wear and tear, misuse or neglect
- repaired or modified without the authorisation of Flexifoil International Ltd
- returned to Flexifoil International Ltd without a valid receipt

If you live in the UK, please return faulty products to your local dealer or Flexifoil International. If you live outside the UK please return faulty products to your distributor. A list of dealers and distributors can be found at [www.flexifoil.com](http://www.flexifoil.com)

### SPECIAL NOTE ON FLYING LINES

Flexifoil will not replace flying lines that have been improperly used, have become worn through normal use or have failed as a result of knots in the line. If kites are flown on flying lines of insufficient breaking strain, the lines will break. Always follow Flexifoil recommendations to ensure that lines of an appropriate breaking strain are used when flying one or more kites.